

Mineral Insulated Heating Cable MIAL

The MIAL range of alloy 825 sheathed Mineral Insulated (MI) heating cable has been developed to meet the specific need for a cable having a high temperature capability and electrical resistance values needed for long circuit lengths. Alloy 825 sheath combined with heating conductors allows to enable an operating temperature of 800°C with resistance values from 2.1Ω/km

down to 36100Ω/km. MI cables have excellent mechanical strength and are intrinsically quite resistant to corrosion. They are series resistance heaters, which must be designed to provide the required heat output. Shipped as cable or ready-made heating units. Heating unit consists of a heating cable, couplings, cold cable inserts, cable glands and flexible installation wires.

Construction

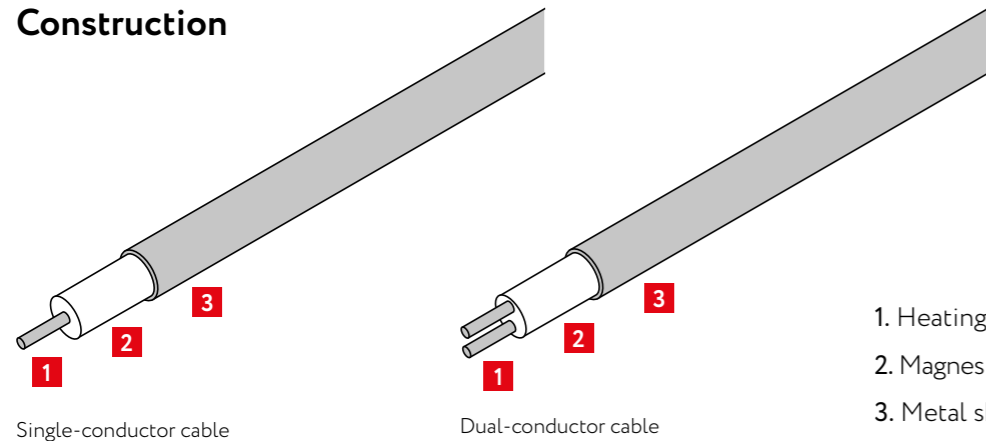

1. Heating Conductor
2. Magnesium Oxide Insulation
3. Metal sheath (Alloy 825)

Application

- Phosphoric acid evaporators pickling-tank heaters
- Metal Forming Industry – Melting of low melt alloys
- Chemical process equipment
- Propeller shafts
- Pickling hooks and equipment
- Tank/vessel Heating
- Spent nuclear fuel element recovery
- Tank trucks

Specification

Heating Units Ordering Code

Example: MI AL-B 16N12220/60/2520/220/E1
Digit: ① ② ③ ④ ⑤ ⑥ ⑦

Digit number	Description	Explication
1	Sheath material	AL
2	Cable configuration	See Table 1
3	Cable reference	See Table 2, 3, 4
4	Cable length	In meter
5	Cable wattage	In Watts
6	Cable voltage	In volt
7	Gland size	See Table 5

Heating Cable Decoding

Example: 1 6 N 12220
Digit: ① ② ③ ④

Digit number	Description	Explication
1	Number of conductors	1 or 2
2	Maximum voltage rating	3=300V, 6=600V
3	Conductor material	K, N
4	Cable resistance × 1000	12220=12.22 Ω/m × 1000

Technical data

Operating voltage	Up to 600 V
Maximum thermal resistance	800 °C
Ex marking	Ex 60079-30-1 IIC T1 to T6 Gb Ex 60079-30-1 IIIIC T450°C to T85°C Db
Resistance at 20 °C	2.1-36100 Ω/m
Construction	1 or 2 conductors

Alloy 825 Sheathed Mineral Insulated Heating Cable

Cable Configurations

Table 1

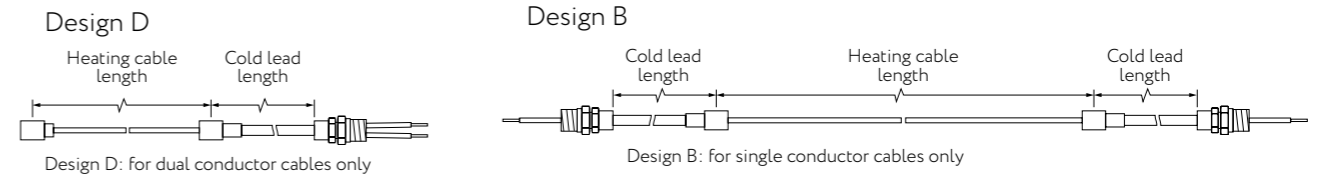

Cable References

Table 2 Single Conductor 600V

Cable ref	Diameter	Resist. at 20 °C Ω/m	Nominal Length	Nominal Weight
	mm		m	kg/km
16C2.1	6.8	0.0021	130	218.0
16C3.4	5.9	0.0034	170	158.1
16C5.3	5.3	0.0053	210	121.8
16C8.5	4.7	0.0085	195	92.4
16C13	4.3	0.013	240	74.3
16C21	4.0	0.021	210	65.4
16K40	5.8	0.04	170	154.9
16K50	5.4	0.05	200	131.9
16K60	5.2	0.06	210	119.9
16K80	4.8	0.08	190	99.4
16K100	4.7	0.1	195	91.9
16K120	4.5	0.12	210	82.2
16N160	6.5	0.16	140	193.9
16N200	5.9	0.2	170	159.7
16N250	5.3	0.25	210	128.9
16N400	4.7	0.4	200	95.9
16N500	4.5	0.5	215	86.0
16N630	4.3	0.63	235	76.6
16N1000	3.9	1.0	290	60.9
16N1600	3.6	1.6	335	50.8
16N2500	3.4	2.5	300	45.5
16N2800	3.4	2.8	300	45.3
16N3300	3.4	3.3	300	45.1
16N4000	3.2	4.0	335	39.9
16N5200	3.2	5.2	335	39.6
16N6300	3.2	6.3	335	39.0
16N10000	3.2	10	335	38.7

Mineral Insulated Heating Cable MIAL

Table 3 Dual Conductor 600V

Cable ref	Diameter	Resist. at 20 °C Ω/m	Nominal Length m	Nominal Weight kg/km
	mm			
26C8.4	9.8	0.0084	60	400.3
26C13.4	8.7	0.0134	75	308.6
26C21	7.9	0.021	95	246.9
26C34	7.3	0.034	110	208.1
26C54	6.3	0.054	145	153.9
26C85	5.6	0.085	185	120.8
26C130	5.3	0.13	215	104.8
26K180	7.9	0.18	95	255.9
26K260	7.4	0.26	105	220.5
26K360	6.8	0.36	130	180.8
26K500	6.4	0.5	145	159.3
26K650	5.9	0.65	165	131.3
26K1000	5.7	1.0	175	124.4
26K1300	6.2	1.3	150	147.3
26K2000	5.8	2.0	170	125.9
26K3300	5.4	3.3	205	109.1
26N4600	5.8	4.6	170	130.3
26N8000	5.4	8.0	205	111.5
26N13000	5.0	13.0	140	95.0
26N27000	4.8	27.0	150	87.1
26N40000	4.6	40.0	160	79.7
26N60000	4.4	60.0	175	72.8
26N72000	4.2	72.0	190	66.3

Table 4 Dual Conductor 300V

Cable ref	Diameter	Resist. at 20 °C Ω/m	Nominal Length m	Nominal Weight kg/km
	mm			
23K210	5.4	0.21	200	118.5
23K300	5.0	0.3	240	99.4
23K400	4.8	0.4	250	90.2
23K480	4.8	0.48	250	89.4
23K650	4.6	0.65	200	82.9
23K1000	4.1	1.0	210	64.8
23K1300	3.8	1.3	240	55.4
23K2000	5.0	2.0	235	97.2
23K2400	4.8	2.4	250	89.3
23K3000	4.6	3.0	200	80.5
23N4600	4.8	4.6	250	89.6
23N7500	4.6	7.5	200	80.0
23N11200	4.4	11.2	180	74.0
23N14000	4.2	14.0	200	67.4
23N18000	3.8	18.0	240	55.1
23N26000	3.6	26.0	270	49.2
23N40000	3.4	40.0	300	43.8
23N50000	3.4	50.0	300	43.7
23N60000	3.4	60.0	300	43.6
23N72000	3.4	72.0	300	43.6

Note: For the required voltage 600 V above application, please contact us.

Alloy 825 Sheathed Mineral Insulated Heating Cable

Gland Size

Table 5

Max. voltage (V)	Design A, D, E			Design B		
	Max. current (amps)	Gland size (English)	(Metric)	Max. current (amps)	Gland size (English)	(Metric)
600	15	E1	M1	20	E1	M1
600	20	E1	M1	25	E1	M1
600	30	E2	M2	40	E2	M2
600	50	E2	M2	70	E2	M2
600	70	E2	M2	100	E2	M2

Note 1: E1 stands for 1/2" NPT; E2 stands for 3/4" NPT; M1 stands for gland diameter M20; M2 stands for gland diameter M25. Stands model shall be advised properly while design.

Note 2: 2-meter-long cold lead is supplied with heating cable. For special requirement, please contact us.

Corrosion Resistance

Table 6

Substance	Recommendation
Sulphuric Acid	Excellent
Hydrochloric Acid	Excellent
Hydrofluoric Acid	Excellent
Phosphoric Acid	Excellent
Nitric Acid	Excellent
Organic Acid	Excellent
Alkalies	Excellent
Sea Water	Excellent
Chloride	Excellent

Explosion Proof

MIAL cable has excellent mechanical strength and high corrosion resistance, can operate in aggressive, hazardous environments, explosive areas included.

Approval



CML 22ATEX3486

IECEX CML 16.0081

Ex 60079-30-1 IIC T1 to T6 Gb

Ex 60079-30-1 IIIC T450oC to T85oC

